

# Battery Product Portfolio

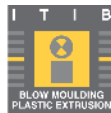

# Agenda

01

**Company Information**

02

**Battery Vents**

03

**Drainage Valves**

04

**Breathers**

05

**Pipes**

06

**Contact**

# Our Locations



**USA, Detroit**



**MEXICO, Cuautla**

Sales, Injection molding, Assembly

**GERMANY, Leutenbach**

Sales & Innovation Management, R&D,  
Project Management, Purchasing

**AUSTRIA, Bischofshofen**

Center of competence Injection molding  
& Process industrialization



**POLAND, Międzyrzecze Górne**

Sales, Extrusion, Corrugation, Thermoforming, Assembly

**SLOVAKIA, Myjava**

R&D, Project Management, Injection molding,  
Assembly, Laboratory & Prototype shop

**ITALY, Paderno**

Sales, R&D, Project Management,  
Corrugation, Blow-molding, Assembly

**INDIA, Chennai**

Sales, R&D, Extrusion, Corrugation and  
Assembly



# Facts



**8 locations** worldwide



**~800** employees



**~86 Mio. €** turnover (2022)



**Holistic system competency** in  
engineering & production



**Certified** according to international  
quality standards

# Customer portfolio



# Reutter Battery Vent Solutions

The battery installation plays a crucial role in Battery Electric Vehicles. To ensure its proper protection, a battery vent, though small, is a powerful component that significantly contributes to the overall performance and safety of the installation. It must consistently perform its duties daily while remaining prepared for sudden thermal events, swiftly relieving pressure from the battery package.

Reutter provides customized engineering solutions that go beyond off-the-shelf options. We offer a wide range of assembly, sealing, and membrane technologies, from standard flame-retardant thermoplastics to advanced high-temperature materials (> 1000°C).

Our innovative solutions include the capability to block battery vents for End-of-Line (EOL) testing or to perform tightness checks on battery packs using the vent system.

Partner with Reutter for reliable and cutting-edge solutions tailored to your specific requirements.

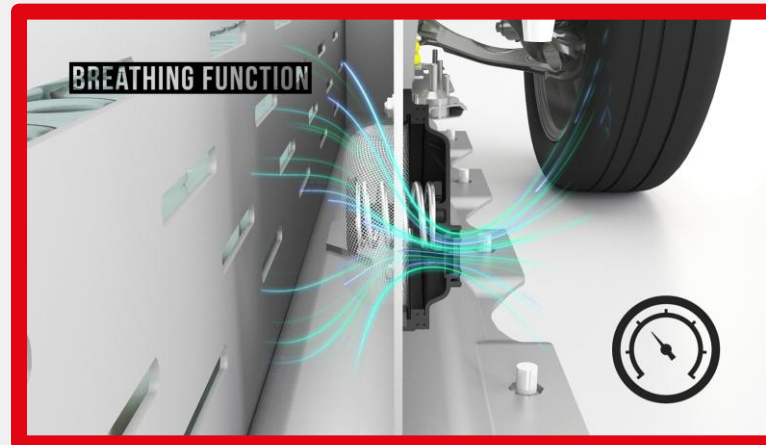

# High Temperature Battery Vent with particle filter

## A100001

 **IP67 & IP69k ingress protection**

 **Mounting with M6 screws** (Assembly torque: 7 Nm)

 **High flow rate capacity:** More than 100 l/s at 300 mbar

 **Breathing function:** >1.4 l/min at 70 mbar

 **Particle filtration:** >0.8 mm (optional)

 **Membrane blockable for EOL tightness testing**

 **High-performance material:** Resistant to high temperatures

 **UL94-V0 conform materials**

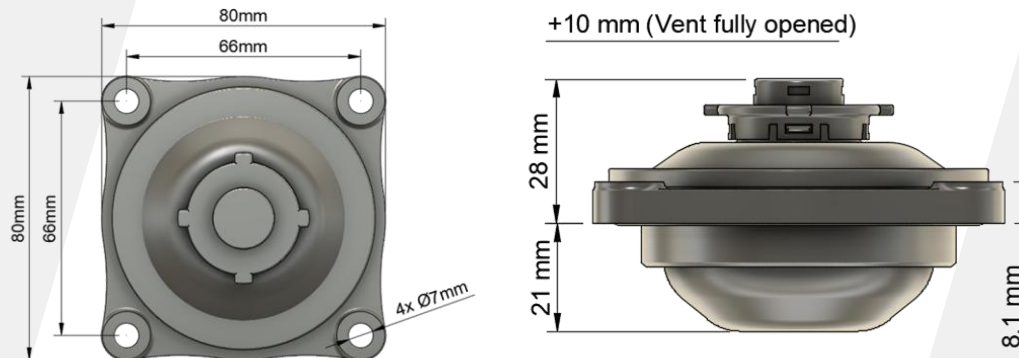

# Battery Vent with EMV and Humidity protection



 **IP67 ingress protection**

 **Mounting with M4 screws** (Assembly torque: 4 Nm)

 **High flow rate capacity:** More than 50 l/s at 300 mbar

 **Breathing function:** 1 l/min at 70 mbar

 **EMV Grid:** Protection against electromagnetic fields

 **Valve function for Membrane:** Reducing humidity entry

 **High-performance plastics**

 **UL94-V0 conform materials**





# Battery Vent M32

## A100003



 IP67 & IP69k ingress protection

 Mounting with thread M32 X 1.5 (M24)

 High flow rate capacity: More than 20 l/s at 300 mbar

 Breathing function: 10 l/min at 70 mbar

 Screw Nut (Optional)

 UL94-V0 conform materials



# Battery Vent Clip In



 **IP67 ingress protection**

 **Clip-in assembly**

 **High flow rate capacity:** More than 3 l/s at 40 mbar

 **Breathing function:** 0.2 l/min at 30 mbar

 **High-performance plastics**

 **UL94-V0 conform materials**



# Battery Vent with bayonet



 **IP67 ingress protection**

 **Bayonet assembly**

 **High flow rate capacity:** More than 14l/s at 300 mbar

 **Breathing function:** 2 l/min at 70 mbar

 **Removal protection:** Requires tool

 **High-performance plastics**

 **UL94-V0 conform materials**



# Reutter Drainage Valves Solutions

The Drainage valve is a crucial component in ensuring the safety and reliability of direct cooled batteries and hardware. This advanced valve ensures optimum performance under the most demanding conditions and is designed to provide robust protection. It manages potential coolant breaches, which is critical in preventing of potential thermal runaway scenarios.

Reutter designs drainage valves tailored to your specific needs. Whether it's **super-absorbent technology** or **electrically controlled** systems, Reutter delivers innovative solutions that exceed expectations.



## Key features

-  IP67 & IP69k ingress protection
-  Clip-in assembly
-  Rapid Coolant Evacuation
-  Reversible or irreversible solution
-  Opening detection by sensor
-  Enhanced Safety
-  High-performance plastics
-  UL94-V0 conform materials

# Reutter Breathers

Engineered to maintain optimal pressure in sealed components, Reutter breathers safeguard against moisture, dust, and contaminants. Ideal for applications like battery enclosures, electric motors, and power electronics, our breathers ensure efficient air exchange while blocking harmful elements.

Reutter offers a versatile range of standard breather solutions and specializes in creating customized designs tailored to your unique requirements. Choose from bayonet, clip-in, or threaded options, each supporting various flow rates and protection levels. With a selection of advanced PTFE membranes, including **PFAS-free** solutions, we ensure superior performance and environmental compliance.

Get in touch with us today to request a solution or explore our breather catalogue!



# Breathers



 **IP67 & IPX9K\*** ingress protection

 **Clip-in or threaded assembly**

 **Oil rating:** 7 (Optional)

 **Breathing function:** 15-70 l/h at 70 mbar

 **High quality materials**

 **Membrane:** PTFE or PET (PFAS free)

 **Sealing Material:** Silicone / EPDM

 **UL94-V0 conform materials possible**



# Reutter Pipe Solutions

In the world of battery electric vehicles and battery installations, efficient thermal management is the key to unlocking peak performance and longevity. From precise cooling pipes for battery packs to cutting-edge solutions for electric motors and critical components, our solutions are designed to keep your systems running smoothly, safely, and efficiently. Our advanced pipes leverage state-of-the-art manufacturing processes, including blow molding (conventional and suction), extrusion and thermoforming, allow us to deliver reliable thermal management solutions for coolant fluid distribution. As your trusted partner, we are dedicated to providing innovative and effective solutions for your cooling needs.

Our advanced extrudable plastic materials offer unmatched advantages: **reduced weight, compact designs compared to traditional rubber**, and exceptional **resistance to extreme temperatures and harsh chemicals**. Designed for durability and efficiency, these plastics are the perfect choice for modern, demanding applications.

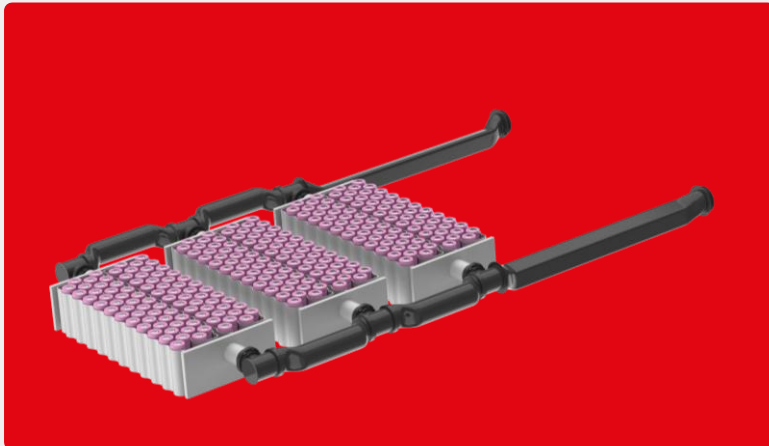

# Production Capability

## Technologie

- Extrusion of smooth and corrugated pipes (Range: Ø4,5 to 200 mm)
- Thermoforming of pipes
- 2D /3D Suction Blow Molding (Up to 3 kg)

## Assembly & Testing

- Quick connector assembly (We cooperate with main QCs market leaders )
- 100% EOL Testing
- Fully and semi-automatic production
- Advanced assembly technology

## Materials:

- HDPE, LDPE, PP or Polyolefins in general
- TPE ThermoPlastic Elastomers (TPV, TPO, TPE, ...)
- PA6 / PA6.12 / PA 12

All extrudable plastic grades on the market.

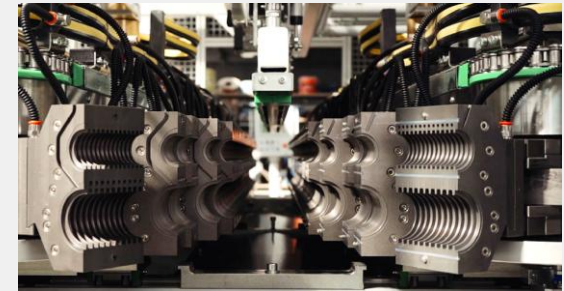



# Contact Us

## **Maximilian Kraus**

Head of Innovation

Reutter GmbH

Hans-Paul-Kaysser Str. 10

71397 Leutenbach

Germany

Mobile: +49 151 18867406

E-Mail: [maximilian.kraus@reutter-group.com](mailto:maximilian.kraus@reutter-group.com)

## **Felix Schulze**

Sales Director

Reutter GmbH

Hans-Paul-Kaysser Str. 10

71397 Leutenbach

Germany

Mobile: +49 172 1788 766

E-Mail: [felix.schulze@reutter-group.com](mailto:felix.schulze@reutter-group.com)

## **Mark Schiefer**

Head of Innovation

Reutter GmbH

Hans-Paul-Kaysser Str. 10

71397 Leutenbach

Germany

Mobile: +49 160 91828 531

E-Mail: [mark.schiefer@reutter-group.com](mailto:mark.schiefer@reutter-group.com)